

PrimeFlo-T Quick Start

Quick Reference Guide – IXD-731-ORG-044/4.0

16 November 2020

Step One

- Avoid installation of sensors in the vicinity of deformations and pipe defects, near welding seams or where deposits could have accumulated.
- Select a measuring point with sufficient straight pipe to obtain accurate measurements. Please consult the manual for the recommended distances from sources of disturbance.
- For a horizontal pipe, mount the sensors on the side of the pipe. For a vertical pipe, mount the sensors at a location where the liquid flows upwards. (Figure 1)

Figure 1: Mounting Points

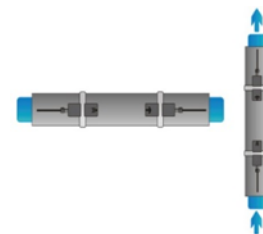
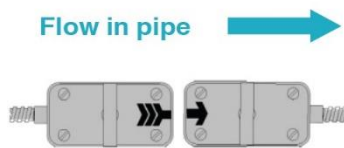



Figure 2: Flow Direction



- Mount the sensors in the direction of the flow. (Figure 2)
- Clean the pipe at the measurement point. Remove loose paint and rust with a wire brush or file.
- Apply coupling paste to the face of the clamp-on sensors before attaching them to the pipe.

Step Two



- Show **NEXT** (1) available item
- **Q_{ON}** (2) = Start totalizer function
- Show next **Display** (3)
- **Q_{OFF}** (8) = Stop totalizer function
- **DIRECT** (9) access to trend plot
- Move menu/selection item **UP**
- Move menu/selection item **DOWN**
- **ESC**ape entry without saving Switch device **OFF** (press > 2 sec.)
-  = ENTER or Switch device ON (press > 2 sec.)

Step Three

The flow meter can be prepared for measurement with the Setup Wizard as found in the Quick start menu.

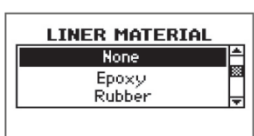
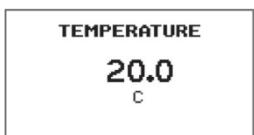
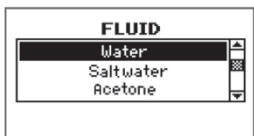
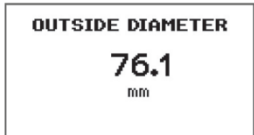
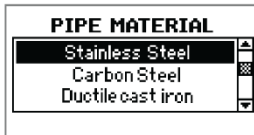
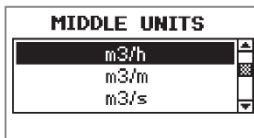
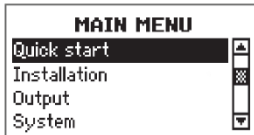

- Upon first power on and the boot up sequence, the Main Menu is displayed.
- Use the UP and DOWN cursor keys to select Quick start and confirm by pressing ENTER.
- Select Setup Wizard to set up the flow meter for measurement. If the sensors are recognised, the serial number will be shown. If not, they can be selected.
- Select the main measurement unit using the cursor keys and confirm with ENTER. This unit will be displayed in the middle of the measurement screen. Selecting OFF deactivates the measurement channel.
- Select the pipe material using the cursor keys and confirm with ENTER.
- Enter the outer pipe diameter using the keypad and confirm with **ENTER**. Use **UP** key as backspace to correct any entry errors. If "0" is entered and confirmed, an additional screen appears that allows entry of the circumference. Press **ENTER** to confirm.
- Enter pipe wall thickness using the keypad and confirm with **ENTER**. Use **UP** key as a back-space to correct for entry errors.
- Select fluid using cursor keys. Confirm by pressing **ENTER**.
- Enter the fluid temperature using the keypad. Confirm by pressing **ENTER**. Use **UP** key as a backspace to correct for entry errors.
- Select pipe liner material using cursor keys and confirm by pressing **ENTER**. If a liner material is chosen, an additional screen appears that allows entry of liner thickness.

Select number of sound passes (sound paths) using cursor keys. **Auto:** Selection by flow meter according to entered parameters (number of passes shown later on Sensor Positioning Screen).

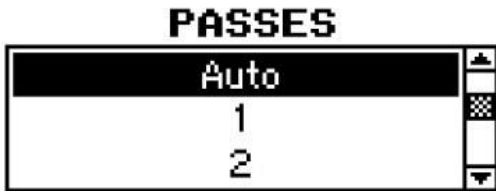

1. 1 pass (diagonal mode)
2. 2 passes (reflection mode)
3. 3 passes (diagonal mode)
4. 4 passes (reflection mode)
5. 5 passes (diagonal mode)

Even number of passes: Both sensors on same side of pipe. Odd number of passes: Sensors on opposite sides (see below for more information). Confirm with **ENTER**.

Reflection Mode

The flow meter uses an even number of passes. This is the most convenient mounting arrangement, as the transducer separation distance can be measured very easily and the sensors can be accurately aligned. Use whenever possible. (Figure 3)

Diagonal mode

Signal travels on odd number of passes through the pipe. Used for larger pipes and for dirty/aerated liquids where greater signal attenuation can occur. The sensor distance on this mounting configuration can be negative (sensors overlapping). (Figure 4)

Figure 3: Reflection Mode

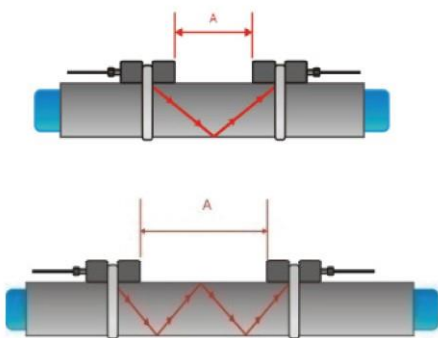
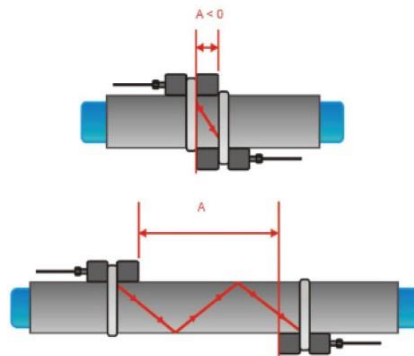

Figure 4: Diagonal Mode



Select **Start Measurement** and confirm with **ENTER** to start the sensor positioning procedure.

Sensor Position Screen

Mount the transducers with the suggested spacing between the inside of the sensor heads. This distance has been determined by the flow meter on the basis of the entered parameters. Use the displayed number of passes to install the sensors on the correct side of the pipe (see modes above). Observe the upper bar (signal-to-noise ratio) and lower bar (signal quality). These should be both filled to about the same level with a filling level of around 1/3 or more desired. Use the moving mark between the two signal bars for the fine adjustment of the sensor position.

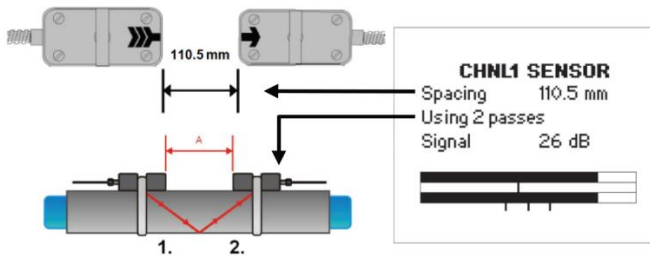

With correct pipe parameters entered and the sensors mounted at the suggested spacing, the mark should be near the central indication line (see three lines below the bottom signal bar). If the mark is to the left-hand side of the central indication line, the sensors are too close to each other. If the mark is to the right, the sensors are too far apart. Slide one sensor carefully along the pipe to bring the mark into a more central position. Measurements can be obtained with the mark being between the left and right indication line. Press **ENTER** to start measurement.

Measurement Screen



- The main measurement unit is displayed when first entering the measurement screen.
- Press **NEXT** to see up to 3 units displayed with the main one in the middle.
- Two further measurement units can be assigned to that screen by going to *Main Menu - Output - Display*.

Totalizer

The totalizer is shown when in measurement mode after pressing **NEXT** three times. It can also be assigned to the three line display, data logger or process outputs by selecting a volumetric unit. The totalizer function is started with **QON** when in measurement mode (measurement screen displayed). Pressing **Q+** resets the total in positive flow direction. Pressing **Q-** resets the total in negative flow direction. The totalizer function can be stopped with **QOFF**. Pressing **QON** again will reset the positive, negative and overall totalizer. Change displays without resetting the totalizer by pressing **DISP** or **NEXT**.

Internal data logger

The data logger is reached via *Main Menu - Output*. It is activated in *Data logger - Interval* by entering and confirming a non-zero value. Enter 0 and Confirm to disable the logger. Up to 10 measurement units can be selected for logging under *Data logger - Selection*. Use the cursor keys to highlight a unit and press **ENTER** to select it. Press 0 to deselect it. An activated data logger is indicated by a document symbol in the top left corner of the display. On start of measurement (measurement screen displayed) the logger records the selected measurement units. A blinking document symbol indicates a recording data logger. Separation markers are set by the data logger whenever a session begins. Leave the measurement screen by pressing **ESC** to stop recording. The recording interval can be changed in *Data logger - Interval*. The data logger is cleared under *Data logger - Log Erase*. Ensure all required data has been downloaded.